

# MODEL 2621

## Voltage Monitor Pick Up Drop Out

- SPDT Output in Standard Relay Configuration
- AC or DC Versions
- Switch Selectable Relay Operation  
Relay On or Off on Low
- Dual Set Points are Ideal in Battery Charging Applications



### DESCRIPTION

The Model 2621 Pick Up Drop Out Voltage Monitor is designed to monitor single phase equipment. The Normal LED indicates the relay is ENERGIZED. Toggle switch settings are as follows:

Switch Position	Lo Trip Set Point	Hi Trip Set Point
Off Lo	Relay De-Energizes	Relay Energizes
On Lo	Relay Energizes	Relay De-Energizes

The Model 2621 is available in AC or DC versions. AC models of the 2621 are not frequency sensitive and can be used on systems from 50 to 400Hz. The voltage set-points are screwdriver adjustable over a wide operating range.

The SPDT output configuration is identical to the configuration of general purpose relays. This unit requires a standard 8-pin socket for mounting.

### DIMENSIONS

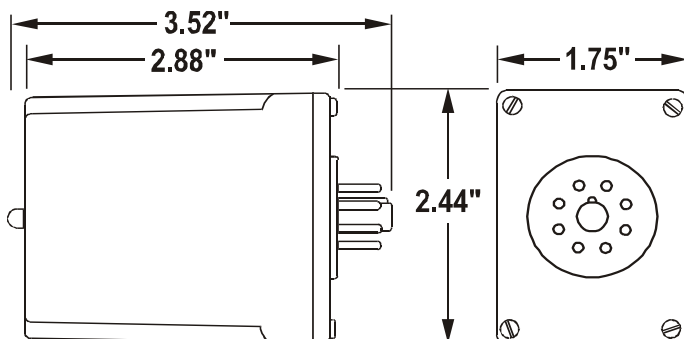

(dimensions have tolerance of  $\pm 0.06$ )

### SPECIFICATIONS

2621 - AC VERSIONS					
Nominal AC voltages	24VAC	120VAC	208VAC	220VAC	240VAC
Max input voltage	32VAC	160VAC	250VAC	264VAC	285VAC
Under voltage range	19-26VAC	90-132VAC	185-229VAC	178-233VAC	200-264VAC
Over voltage range	22-29VAC	108-150VAC	187-240VAC	198-242VAC	216-270VAC
Input frequency (Hz)	50 - 400Hz				
2621 - DC VERSIONS					
Nominal DC Voltage	12VDC	24VDC	28VDC	48VDC	110VDC
Max input voltage	17VDC	32VDC	37VDC	62VDC	145VDC
Under voltage range	10-13VDC	19-26VDC	22-30VDC	38-50VDC	85-121VDC
Over voltage range	11-15VDC	22-29VDC	25-34VDC	43-58VDC	99-135VDC
2621 - ALL VERSIONS					
Power consumption	$\pm 2$ watts max				
Set-point stability	$\pm 0.5\%$ of set-point				
Polarity protection	DC versions only				
Trip response	0.5 sec fixed ( $\pm 0.1$ sec)				
Reset time	0.1 sec				
Output contacts	SPDT				
Contact rating	10A at 240VAC resistive				
Expected relay life	Mechanical: 10 million operations Electrical: 100,000 at rated load				
Operating temp	- 14° to +122°F				
Humidity tolerance	97% w/o condensation				
Mounting	8-pin socket (*order separately)				
Case material	ABS plastic				
Weight	5 oz.				

\* Order 8-pin socket number 51X120

### PIN DRAWING

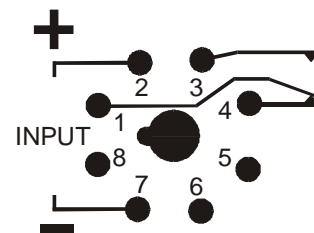

Shown De-Energized

Main (918) 438-1220  
Sales (800) 862-2875



11440 East Pine Street  
Tulsa, Oklahoma 74116

09/2016  
© 2016 TIME MARK CORPORATION

TIME MARK is a division of  AEMT, Inc.

# MODEL 2621 Voltage Monitor

READ ALL INSTRUCTIONS BEFORE INSTALLING, OPERATING OR SERVICING THIS DEVICE.  
KEEP THIS DATA SHEET FOR FUTURE REFERENCE.

## GENERAL SAFETY

POTENTIALLY HAZARDOUS VOLTAGES ARE PRESENT AT THE TERMINALS OF THE MODEL 2621 MONITORS.  
ALL ELECTRICAL POWER SHOULD BE REMOVED WHEN CONNECTING OR DISCONNECTING WIRING.  
THIS DEVICE SHOULD BE INSTALLED AND SERVICED BY QUALIFIED PERSONNEL.

## Installation Instructions

### INSTALLATION

The Model 2621 is a socket-mounted dual set point voltage monitor. The pin configuration diagram on the unit shows the contacts in the power OFF, or tripped condition.

Connect the wiring to the socket as shown in the Typical Application diagram. **Observe the proper polarity of the input voltage for DC models.**

### ADJUSTMENT PROCEDURE

When adjusting the Model 2621 you may wish to jumper or disconnect the control circuit contacts to prevent tripping the load on and off. A variable voltage source and a digital voltmeter provide the most accurate means of calibrating the trip point setting.

Set the toggle switch on top of the unit to the desired operation of the relay. (Relay on at low trip or relay off at low trip)

Rotate the LO TRIP ADJUST to the desired low setting.  
Rotate the HI TRIP ADJUST to the desired high setting.

Allow the system to operate. If the unit doesn't trip at the desired voltage, adjust the HI or LO trip in small increments. Turn clockwise to raise the trip voltage or counterclockwise to lower the trip voltage. **Do not overlap HI and LO set-points or unit will remain in a trip condition.**

**NOTE:** When installing the Model 2621 monitor in areas of high humidity or contamination, it is recommended that the base area and all exposed metal parts of the socket be coated liberally with a good quality silicone grease, such as Dow Corning DC-4 or DC-4X. Insert the unit into the socket and wipe off excess grease around the base. This will prevent the entrance of moisture and other contaminants into the base and socket areas.

### TROUBLESHOOTING

Check that voltage is present and is of the correct level. Check all fuses, and verify that all wiring connections are correct. Verify trip and pickup voltages aren't overlapping. Should problems persist, contact your local Time Mark Distributor, or the factory at 800-862-2875 (Monday-Friday; 8 a.m. to 5 p.m. CST), for further assistance.

### TYPICAL APPLICATION - AC Power

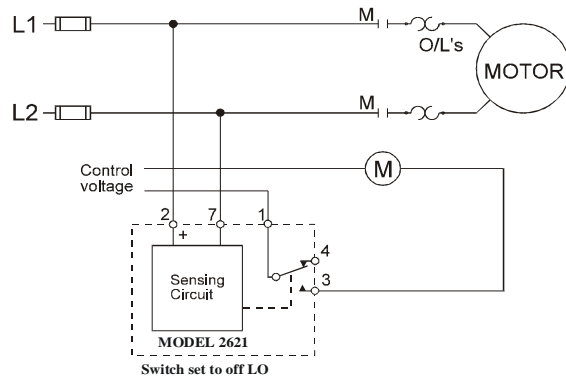

Shows No Power Applied

### TYPICAL APPLICATION - DC Power

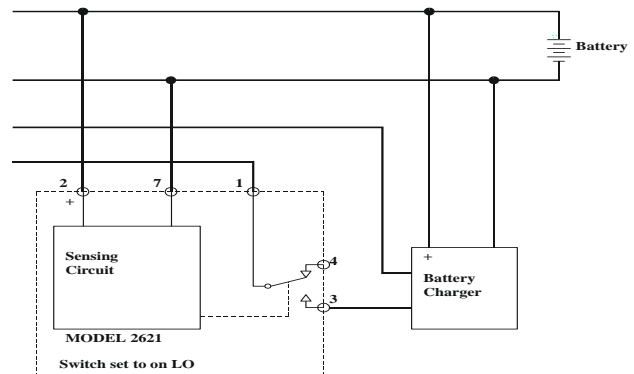

Shows No Power Applied

### WARRANTY

This product is warranted to be free from defects in materials and workmanship, and is covered by our exclusive **5-year Unconditional Warranty**. Should this device fail to operate for any reason, we will repair it for five years from the date of manufacture. For complete warranty details, see the *Terms and Conditions of Sales* page in the front section of the Time Mark catalog or contact Time Mark at 1-800-862-2875.

Main (918) 438-1220  
Sales (800) 862-2875



11440 East Pine Street  
Tulsa, Oklahoma 74116

09/2016  
© 2016 TIME MARK CORPORATION

TIME MARK is a division of  AEMT, Inc.